

BULK FLOW CONVEYOR CHAIN

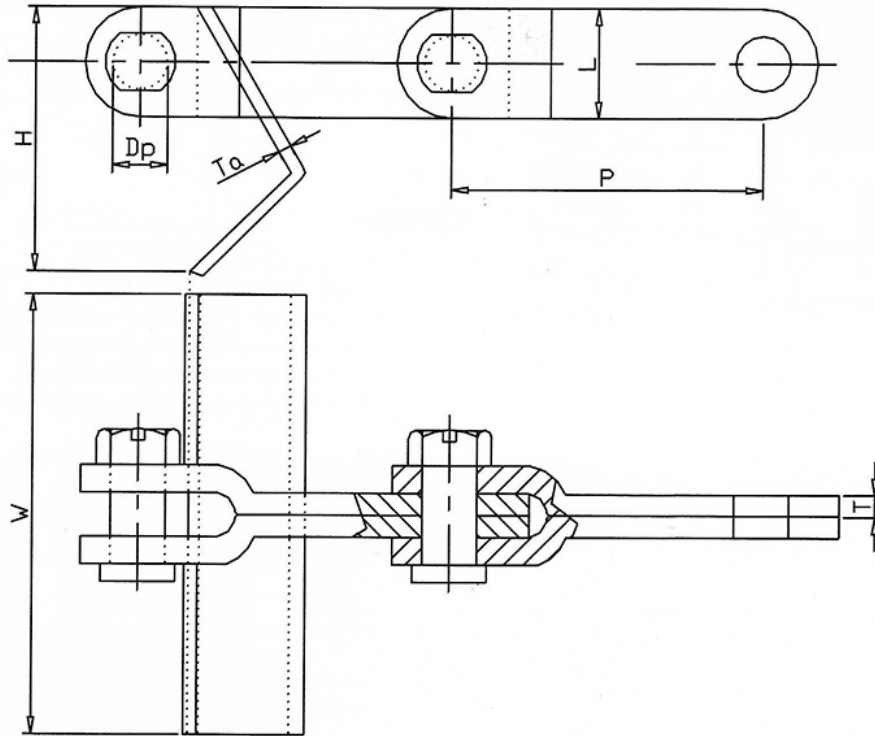

Cat No.	Pitch (P)	Breaking Load(in KG)	Height of Link (H)	Thickness of Link (T)	Diameter Pin(Dp)	Width (W) Max
RB 201	142mm	20,000	50	6	20	380
RB 202	142mm	24,500	50	8	23	480
RB 203	142mm	28,000	50	10	24	580
RB 204	142mm	32,000	50	12	25	580
RB 205	4"	11,000	40	6	15.8	230
RB 206	142mm	38,000	60	12	25	580

*all unspecified dimensions in mm

Note :

1. Types of Chain Locking
 - a) Split Pin Locking
 - b) Castle Nut With Split Pin Locking.
2. Case hardened materials used for making pins.
3. Customer has to specify H, W, Ta, Dp, T and P